

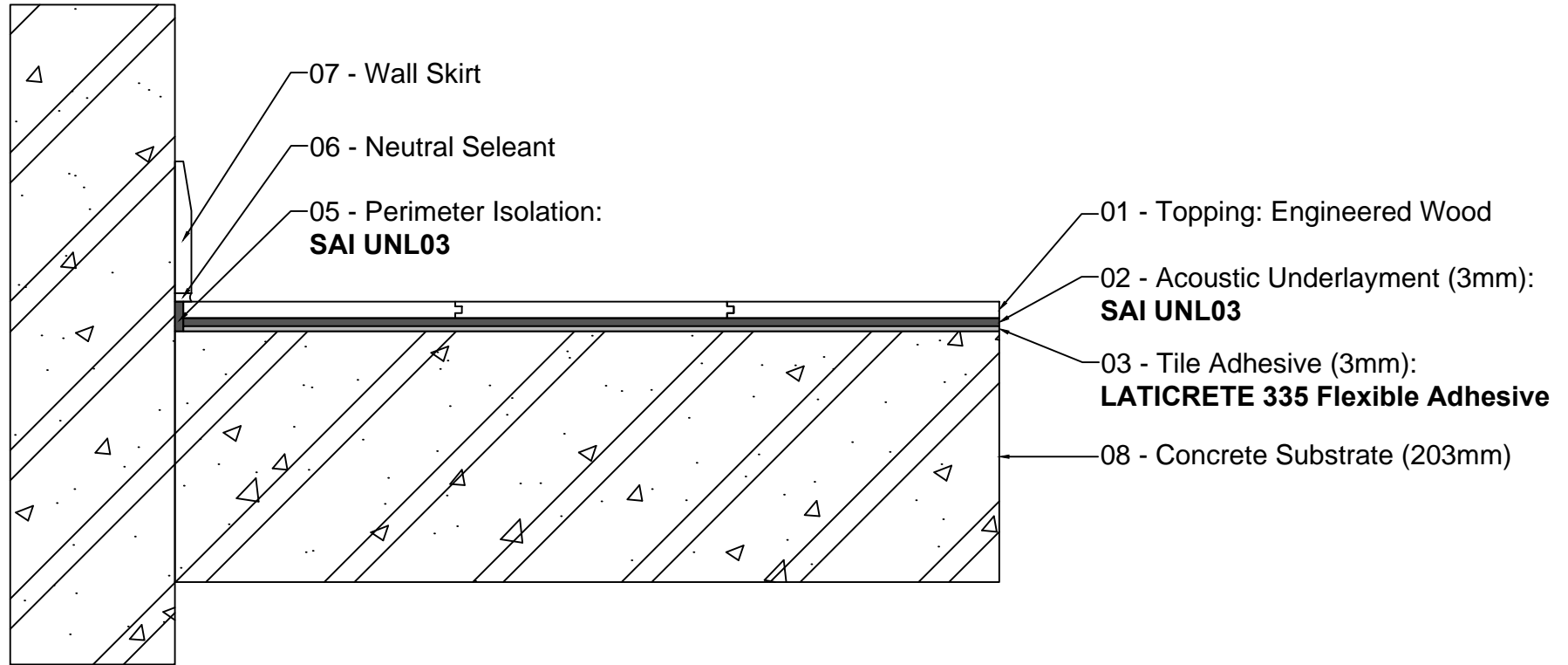

SAI UNL03
IMPACT & AIRBORNE NOISE CONTROL SYSTEM
 For Engineered Wood Finished Floors



 <p>VK ASIA Innovative Building Materials</p> <p>VK Asia Company Limited Mobile Zalo Whatsapp: 098 132 0674 Email: vkasiaco@gmail.com Internet: vkasia.vn</p>	ACOUSTIC APPLICATION	ASSEMBLY INFORMATION		ACOUSTIC PERFORMANCE (Without suspended Ceiling)	
	IMPACT & AIRBORNE NOISE CONTROL SYSTEM	Floor Topping:	Engineered Wood		<div style="display: flex; justify-content: space-around; align-items: center;"> <div style="border: 1px solid black; border-radius: 50%; padding: 10px; text-align: center;"> 57 IIC </div> <div style="border: 1px solid black; border-radius: 50%; padding: 10px; text-align: center;"> 54 STC </div> </div>
		Acoustic Underlayment:	SAI UNL03		
		Installation:	Under Floor Topping		
		Installation Method:	Bonded		
Application Area:	Dry				